

THESE DRAWINGS ARE THE PROPERTY OF QUALTEK ELECTRONICS AND NOT TO BE REPRODUCED FOR OR COMMUNICATED TO A THIRD PARTY WITHOUT THE EXPRESS WRITTEN PERMISSION OF AN OFFICER OF QUALTEK ELECTRONICS.

| REVISION | | | |
|----------|-----------------|----------|----------|
| REV. | DESCRIPTION | DATE | APPROVED |
| B | RoHS Compliancy | 06-01-06 | DP |
| C | Graphics Update | 03-20-08 | DP |

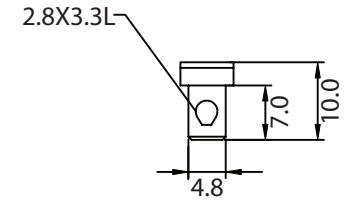
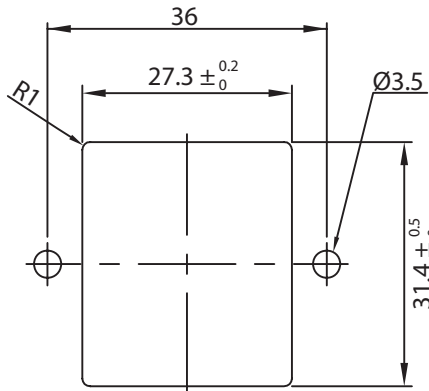
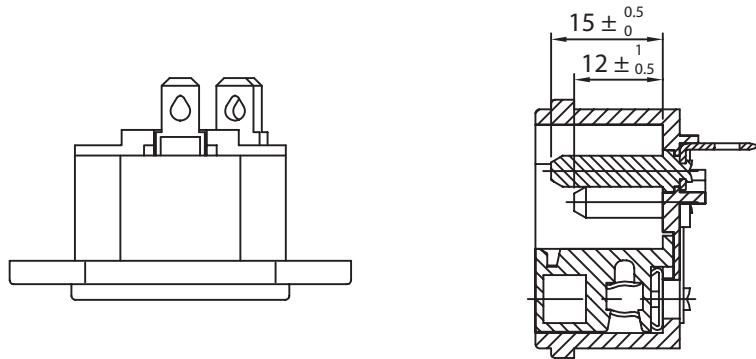
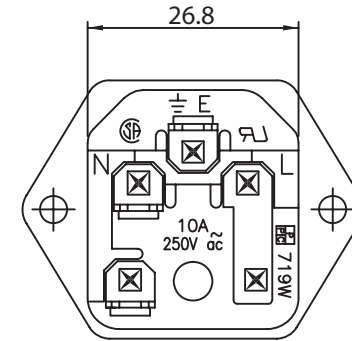
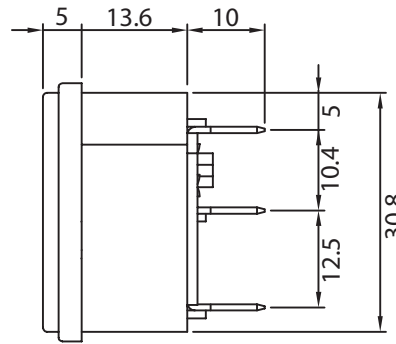
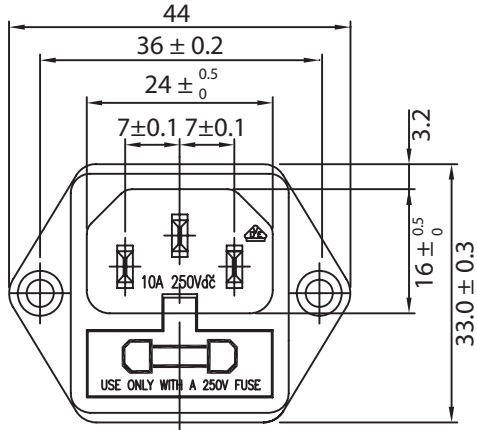

PANEL CUTOUT

NOTES:

MATERIAL:

- MOULDING: NYLON, FLAMMABILITY RATING UL 94 V-0
- CONTACTS: BRASS, PINS NICKEL PLATED, TAGS TIN PLATED
- RATING: 10A 250V AC
- CONTACT RESISTANCE: <10m OHM
- INSULATION RESISTANCE: >100M OHM 500VDC MIN
- DIELECTRICS STRENGTH: 2000VAC/1mA 1MIN
- A.C. BREAKDOWN:
 - POLE-POLE: 5kV
 - POLES-PANEL: 4.0kV
- OPERATING TEMPERATURE: -40 °C TO +70 °C
- MAX. PIN TEMPERATURE: +65 °C
- APPROVALS: UL, CSA, VDE
- DUAL FUSEHOLDER, ONE ACTIVE, ONE SPARE
- FUSES NOT INCLUDED - RECOMMENDED SIZE: 5 X 20mm
- RoHS COMPLIANT

CONTROLLED

| Dim range (mm) | Tolerance +/- (mm) | Qualtek Electronics Corp. PPC DIVISION | | |
|----------------|--------------------|---|----------------|-----------------|
| | | Part Number: | 719W-00/03 | RoHS Compliant |
| 0-1 | 0.15 | Description: AC RECEPTACLE | | |
| 1-6 | 0.20 | | | |
| 6-18 | 0.30 | | UNIT: mm | REV. C |
| 18-50 | 0.50 | | | |
| 50-120 | 0.70 | Drawn / Date | Checked / Date | Approved / Date |
| 120-250 | 0.90 | B.Zhang 08-28-02 | 08-28-02 | JJH / 08-28-02 |
| 250-500 | 1.20 | | | |